

Pooyan Hydraulics II

By: Amir vahabzadeh

Electrohydraulic Valves...
A Technical Look

Vahabzade@yahoo.com

Cell: 0912 304 68 04

ELECTROHYDRAULIC VALVE APPLICATIONS

APPLICATIONS

Industrial

Basic Metal Processing
Blow/Injection Molding
Earthquake Simulation
Entertainment Equipment
Fatigue Testing
Flight Simulation
Gas, Steam & Hydro Turbines
Machine Tools
Manufacturing Systems
Material Testing
Paper Machines
Robotics
Rubber Processing
Saw & Veneer Mill Machines
Steel & Aluminum Mill Equipment

Mobile/Marine

Active Suspension
Forestry Machines
Mining Machinery
Railroads
Remote Control
Seismic Exploration
Ships
Submersibles
Vibration Reduction

Applications

ELECTROHYDRAULIC VALVE SELECTION GUIDE

Selection

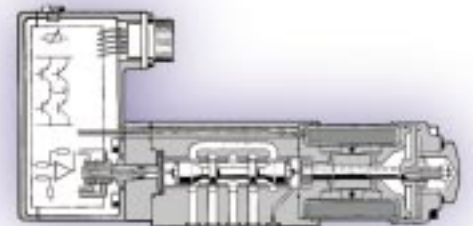
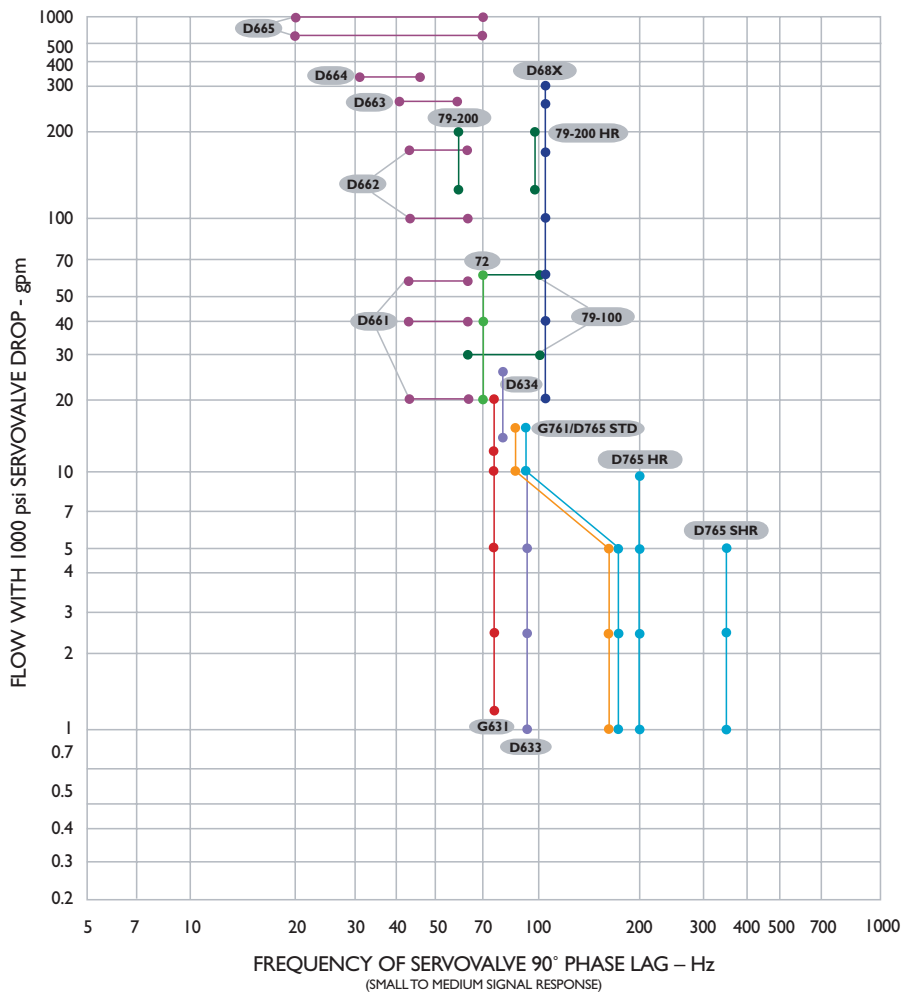

DDV VALVE

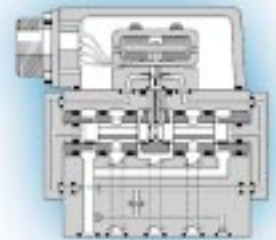

SERVOVALVE

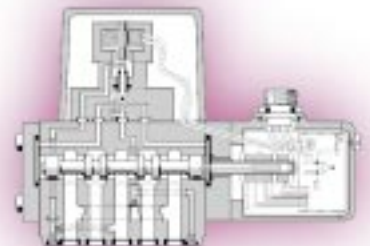

SERVOJET®

HOW TO SELECT A SERVO OR PROPORTIONAL VALVE

DETERMINE THE REQUIRED VALVE FLOW RATE AND FREQUENCY RESPONSE

- a) In order to compensate for unknown forces, size the actuator area to produce a stall force 30% greater than the desired force to the supply pressure available.

$$A = \frac{1.3 F_R}{P_S}$$

where:
 A = actuator area (in²)
 F_R = force required to move the load (lb) at maximum velocity, ref. key parameters
 P_S = supply pressure (psi)

Refer to the NFPA standard cylinder bore and rod sizes and select the area closest to the result of the above calculations.

- b) From the maximum required loaded velocity and the actuator area from the above calculation, determine the valve loaded flow and the load pressure drop.

$$Q_L = A X_L$$

where:
 Q_L = loaded flow (in³/sec)
 X_L = maximum required loaded velocity (in/sec)

$$P_L = \frac{F_R}{A}$$

where:
 P_L = load pressure drop (psi)

- c) Compute the no-load flow.

$$Q_{NL} = Q_L \sqrt{\frac{P_S}{P_S - P_L}}$$

where:
 Q_{NL} = no-load flow (in³/sec)

- d) Determine the valve rated flow at 1,000 psi valve drop for Servovalves and 150 psi valve drop for Proportional Valves. Increase by 10% for margin.

$$Q_R = 1.1 \left(\frac{Q_{NL}}{3.8} \right)$$

10% pad
 in³/sec to gpm conversion

where:
 Q_R = Servovalve rated flow (gpm) at 1,000 psi drop or Proportional Valve rated flow at 150 psi drop

- e) For open-loop control, a valve having a 90° phase lag at 3 Hz or higher, should be adequate.
- f) For closed loop control of systems utilizing electrical feedback, calculate the load natural frequency using the equations in this brochure under "Load Resonant Frequency". The optimum performance will be achieved if the Servovalve 90° phase point exceeds the load resonant frequency by a factor of three or more.
- g) With a calculated flow rate and frequency response, reference the Valve Selection Table on page 3 for valve selection. Any Servovalve that has equal or higher flow capacity and response will be an acceptable choice. However, it is preferable not to oversize the Servovalve flow capacity as this will needlessly reduce system accuracy.
- h) Consult individual data sheets for complete valve performance parameters.

KEY PARAMETERS FOR SERVO OR PROPORTIONAL VALVE SELECTION

Supply Pressure

Servovalve and ServoJet® Valves are intended to operate with constant supply pressure and require continuous pilot flow to maintain the hydraulic bridge balance. The supply pressure should be set so that the pressure drop across the valve is equal to one-third of the supply pressure. The flow capacity should include the continuous pilot flow to maintain the hydraulic bridge balance. Direct Drive Valve performance is constant no matter what the supply pressure. Therefore, they are good in systems with fluctuating supply pressures.

Standard Moog Inc. valves will operate at supply pressures from 200 to 3,000 psi. Optional valves for 50 to 5,000 psi operation are available. Refer to individual valve specifications.

Type of Fluid

Moog Inc. valves operate most effectively with fluids that exhibit a viscosity of 60 to 450 SUS at 100°F. Due to the Servovalve operating range of -40°F to 275°F, care should be taken to assure fluid viscosity does not exceed 6,000 SUS. In addition, fluid cleanliness is of prime importance and should be maintained at ISO DIS 4406 Code 16/13 max, 14/11 recommended. Consult the Moog Inc. Filtration and Valve Series catalogs for recommendations.

Fluid compatibility with material used in the construction of valves must be considered. Contact the factory for specific information.

Force Requirements

In most applications, a portion of the available supply pressure must be used to overcome some force. Since valve flow ratings are given as a function of pressure drop across the valve, total force requirements must be known in order to determine what portion of the supply pressure is available to be dropped across the valve. Total force is the summation of all individual forces that occur due to the static or dynamic configuration of the system.

$$F_R = F_L + F_A + F_E + F_S$$

where:
 F_R = total required force (lb)
 F_L = force due to load (lb)
 F_A = force due to acceleration (lb)
 F_E = force due to external disturbance (lb)
 F_S = force due to seal friction (lb)

Force Due to a Load

Force due to a load F_L can be an aiding or resistive component, depending upon the load's orientation and direction of travel. Consideration has to be taken when computing F_L to ensure the proper external friction coefficients and resolved forces are used.

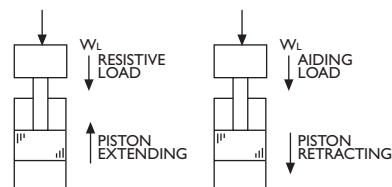

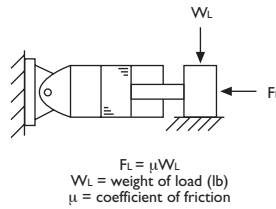
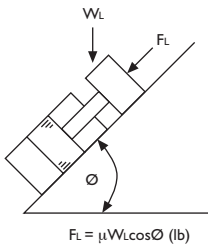

Force Due to Acceleration

The forces required to overcome inertia become very large in high speed applications and are critical to valve sizing.

$$F_A = Ma$$

$$a = \frac{V_{MAX}}{T_a}$$

$$M = \frac{W_L + W_P}{g}$$

where:

M = mass (lb - sec²/in)

a = acceleration (in/sec²)

W_P = weight of piston (lb)

V_{MAX} = maximum velocity (in/sec)

T_a = time period for acceleration (sec)

W_L = weight of load

Force Due to External Disturbances

These forces can be generated by constant or intermittent sources.

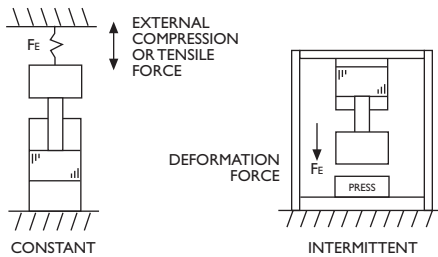

Force Due to Seal Friction

Most valves are used on applications which employ some sort of motion device. These motion devices usually utilize elastomer seals to separate the various pressure chambers. The friction between these seals and the moving parts acts as opposing force.

$$F_S = 0.1 F_{MAX}$$

where:

F_{MAX} = stall force (lb)

Standard practice involves setting seal friction at 10% of the maximum force available, unless absolute values are known.

Dynamic Response

TYPICAL BODE PLOT OF DYNAMIC RESPONSE

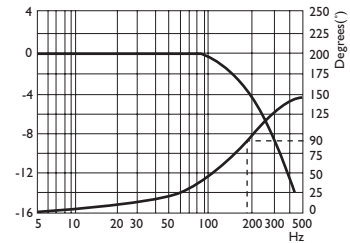

A valve's dynamic response can be easily determined by measuring the frequency at which the phase lag between the input current and output flow reaches 90° (90° phase lag point). The frequency response will vary with input signal amplitude, supply pressure, and fluid temperature. Therefore, comparisons must use consistent data. The recommended peak-to-peak signal amplitude is 80% of the valve rated current. Servo valve and Servojet® response will improve somewhat with higher supply pressure, and generally depreciate at both high and low temperatures. Direct Drive Valve response is independent of supply pressure.

Load Resonant Frequency

Open loop control consists of a human operator monitoring the parameter (i.e., position or speed) and varying the input of the control valve to obtain the desired result. Closed loop control is capable of fast, more accurate control and requires a high performance control valve. For optimum performance, the valves 90° phase point should exceed the load resonant frequency by a factor of three or more. Load resonance is determined by the overall stiffness (K_A), which is the combination of the hydraulic stiffness (K_O) and the structural stiffness (K_S), given by:

$$K_A = \frac{K_O K_S (\text{lb/in})}{K_O + K_S}$$

The load resonant frequency for an equal area cylinder is given by:

$$f_N = \frac{1}{2\pi} \sqrt{\frac{K_O}{M}}$$

where:

f_N = load resonant frequency (Hz)

K_O = hydraulic stiffness (lb/in)

where:

β = bulk modulus of fluid used (psi)

A = working area of double ended piston (in²)

X_T = total piston stroke (in)

where:

σ = actuator volumetric efficiency

X_u = piston stroke used for application (in)

V = total volume of fluid between valve control ports and the piston (in³)

$$\sigma = \frac{AX_u}{V}$$

NOTE: Typical bulk modulus (β) ≈ 2.0 × 10⁵ psi

ELECTROHYDRAULIC VALVE PILOT STAGE AND SPOOL ACTUATION TECHNOLOGIES

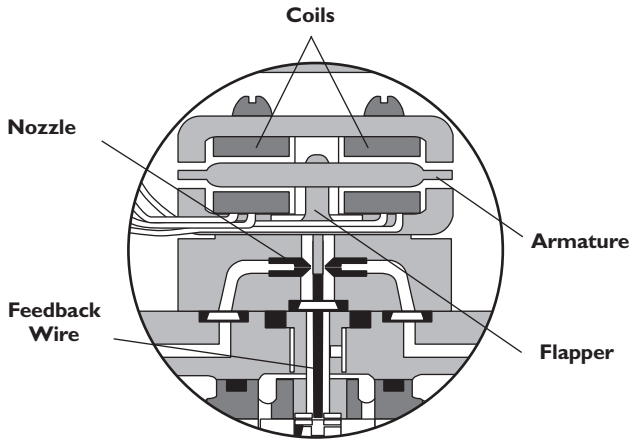

NOZZLE FLAPPER TORQUE MOTOR DESCRIPTION

An electrical command signal (flow rate set point) is applied to the torque motor coils and creates a magnetic force which acts on the ends of the pilot stage armature. This causes a deflection of armature/flapper assembly within the flexure tube. Deflection of the flapper restricts fluid flow through one nozzle which is carried through to one spool end, displacing the spool. [Spool actuation relative to valve operation is detailed on page 17]

Movement of the spool opens the supply pressure port (P) to one control port while simultaneously opening the tank port (T) to the other control port. The spool motion also applies a force to the cantilever spring, creating a restoring torque on the armature/flapper assembly.

Once the restoring torque becomes equal to the torque from the magnetic forces, the armature/flapper assembly moves back to the neutral position, and the spool is held open in a state of equilibrium until the command signal changes to a new level.

In summary, the spool position is proportional to the input current and, with constant pressure drop across the valve, flow to the load is proportional to the spool position.

Technology

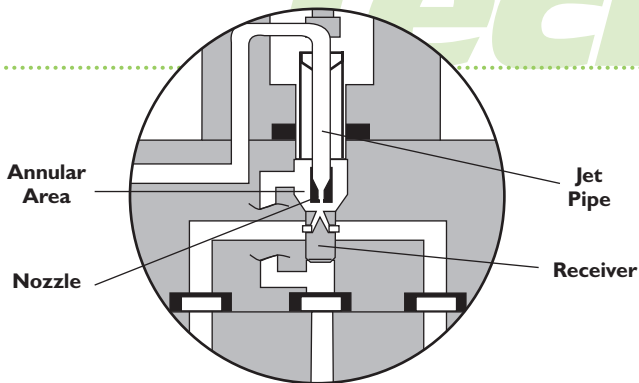

SERVOJET® DESCRIPTION

The ServoJet® pilot stage consists mainly of torque motor, jet pipe and receiver. A current through the coil displaces the jet pipe from its neutral position. This displacement, combined with the special shape of the jet pipe, directs a focused fluid jet towards one side of the receiver.

The jet now produces a pressure difference across the ends of the spool. This pressure difference causes a spool displacement which, in turn, results in control port flow. The pilot stage drain is through the annular area around the nozzle to tank.

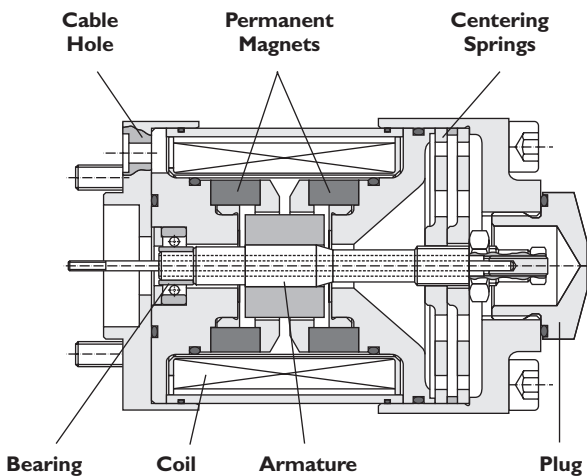

LINEAR FORCE MOTOR DESCRIPTION

Moog's Direct Drive Valves use our proprietary linear force motor. A linear force motor is a permanent magnet differential motor. The permanent magnets provide part of the required magnetic force. The linear force motor has a neutral mid-position from which it generates force and stroke in both directions. Force and stroke are proportional to current.

High spring stiffness and the resulting centering force, plus external forces (i.e. flow forces, friction forces due to contamination), must be overcome during outstroking. During backstroking to center position, the spring force adds to the motor force and provides additional spool driving force making the valve less contamination sensitive. The linear force motor requires very low current in the spring centered position.

TYPES OF SERVO SYSTEMS

POSITION SERVO SYSTEM

A load positioning servo system is comprised of a Servo, ServoJet® or Direct Drive Valve, actuator, position feedback transducer, position command generator, and a Servoamplifier. A typical linear position servo system using a double-ended piston is shown to the right (a rotary position servo system can be created by substituting the appropriate rotary components).

The valve's two output control ports are connected across the load cylinder. In the Servoamplifier, the command input is compared to the present position output of the position transducer. If a difference between the two exists, it is amplified and fed to the valve as an error signal. The signal shifts the valve spool position, adjusting flow to the actuator until the position output agrees with the command input.

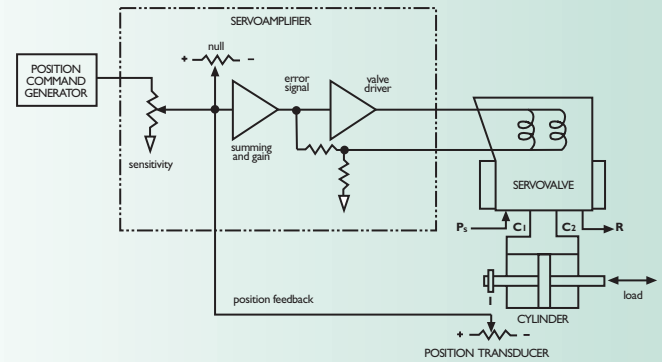

TYPICAL POSITION SERVO

VELOCITY SERVO SYSTEM

A velocity servo system is comprised of a Servo, ServoJet® or Direct Drive Valve, hydraulic motor, tachometer, velocity command generator, and a Servoamplifier whose summing and gain amplifier are configured to also act as an integrating amplifier. A typical rotary servo system is shown to the right (a linear velocity servo system can be created by substituting the appropriate linear components).

The valve's two output control ports are connected across the hydraulic motor. In the Servoamplifier, the command input is compared to the present velocity output of the tachometer. If a difference between the two exists, it is integrated over time and subsequently fed to the valve as an error signal. This signal shifts the valve spool position, adjusting flow to the motor until the velocity output agrees with the command input.

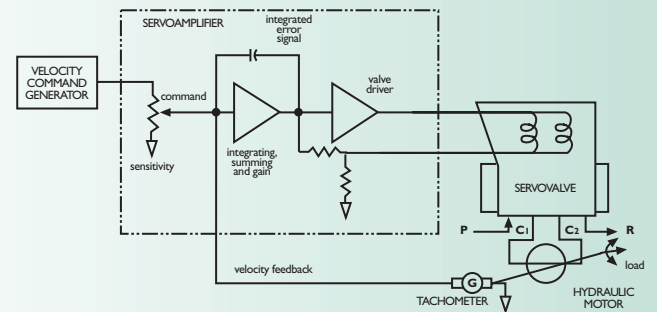

TYPICAL VELOCITY SERVO

FORCE SERVO SYSTEM

A force servo system can be created with a Servo, ServoJet® or Direct Drive Valve, actuator, load cell or pressure transducer, and a Servoamplifier (an Adjustable Metering Orifice may be used to improve system performance). A typical force servo system is shown to the right.

The valve's two output control ports are connected across the cylinder. In the Servoamplifier, the command input is compared to the present force output of the load cell. If a difference between the two exists, it is amplified and fed to the valve as an error signal. The signal shifts the valve spool position, adjusting pressure to the actuator until the force output agrees with the command input.

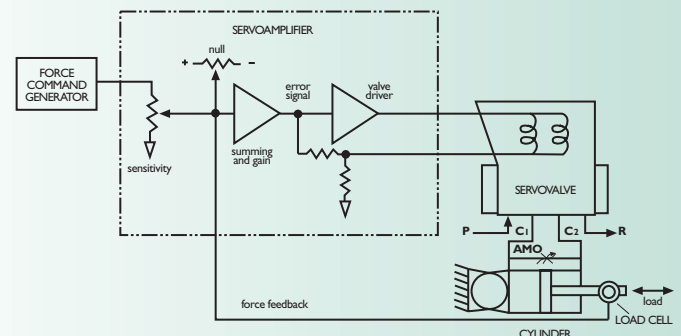

TYPICAL FORCE SERVO

GENERAL TERMINOLOGY

ELECTRICAL

Input Current – The electrical current to the valve which commands control flow, expressed in milliamperes (mA).

Rated Current – The specified input of either polarity to produce rated flow, expressed in milliamperes (mA). Rated current is specified for a particular coil configuration (differential, series, individual or parallel coils) and does not include null bias current.

Coil Impedance – The complex ratio of coil voltage to current. Coil impedance will vary with signal frequency, amplitude, and other operating conditions, but can be approximated by the DC coil resistance R, expressed in ohms(Ω) and the apparent coil inductance L, expressed in henrys (H), measured at a specific signal frequency.

Dither – An AC signal sometimes superimposed on the valve input to improve system resolution. Dither is expressed by the dither frequency hertz (Hz) and the peak-to-peak dither current, expressed in milliamperes (mA).

Terminology

Units:

Recommended English and Metric units for expressing valve performance include the following:

CATEGORY	ENGLISH	METRIC	CONVERSION FACTORS
Fluid Flow	in ³ /sec (cis) gal/min (gpm)	liters/min (lpm)	0.98 lpm/cis 3.85 cis/gpm 3.78 lpm/gpm
Fluid Pressure	lb/in ² (psi)	bar	0.069 bar/psi
Dimensions	inches (in)	millimeters (mm) micrometers (μ m)	25.4 mm/in 25400 μ m/in
Weight	pounds (lb)	kilograms (kg)	0.454 kg/lb
Torque	in-lb	Newton meters (N-m)	0.113 N-m/in-lb
Temperature	degrees Fahrenheit ($^{\circ}$ F)	degrees Celsius ($^{\circ}$ C)	$^{\circ}$ C = $\frac{5}{9}$ ($^{\circ}$ F – 32)

HYDRAULIC

Control Flow Q_v – The flow through the valve control ports to the load expressed in in³/sec (cis), gal/min (gpm), or liters/min (lpm).

Rated Flow Q_R – Servovalves are typically rated at 1,000 psi drop, while Proportional Valves are rated at 150 psi drop. The flow under no-load condition, Q_{NL} , will vary with supply pressure as shown in Figure 1. The relationship can be calculated by:

$$Q_{NL} = Q_R \sqrt{\frac{P_s}{\Delta P}}$$

where:
 Q_{NL} = no-load flow
 P_s = supply pressure
 Q_R = Servovalve rated flow at 1,000 psi drop, P.V.
 rated flow at 150 psi drop
 ΔP = valve drop, typically 1,000 psi for Servovalves and 150 psi for Proportional Valves

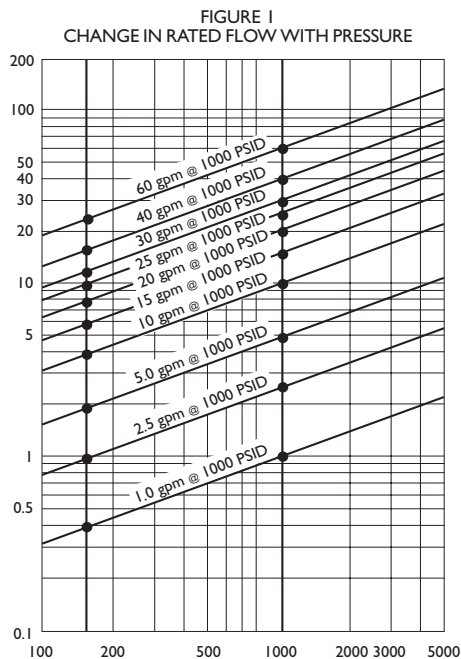

Flow Gain – The normal relationship of control flow to input current, expressed as cis/mA, gpm/mA, or lpm/mA.

No Load Flow – The control flow with zero load pressure drop, expressed in cis, gpm, or lpm.

Internal Leakage – The total internal valve flow from pressure to return with zero control flow (usually measured with control ports blocked), expressed in cis, gpm, or lpm. Leakage flow will vary with input current, generally being a maximum at the zero level of null (called null leakage).

Load Pressure Drop ΔP_L – The differential pressure between the control ports (that is, across the load actuator), expressed in lbs/in² (psi) or bar.

Valve Pressure Drop ΔP_v – The sum of the differential pressure across the control orifices of the valve spool, expressed in psi or bar. Valve pressure drop will equal the supply pressure, minus the return pressure, minus the load pressure drop, [$\Delta P_v = (P_s - R) - \Delta P_L$].

PERFORMANCE

Linearity – The maximum deviation from control flow from the best straight line of flow gain, expressed as percent of rated current.

Symmetry – The degree of equality between the flow gain of one polarity and that of reversed polarity. Measured as the difference in flow gain for each polarity, expressed as percent of the greater.

Hysteresis – The difference in valve input currents required to produce the same valve output as the valve is slowly cycled between plus and minus rated current.

Threshold – The increment of input current required to produce a change in valve output. Valve threshold is usually measured as the current increment required to change from an increasing output to a decreasing output, expressed as percent of rated current.

Lap – In a sliding spool valve, the relative axial position relationship between the fixed and moveable flow-metering edges within the null region. Lap is measured as the total separation at zero flow of straight line extensions of nearly straight portions of the flow curve.

Pressure Gain – The change of load pressure drop with change of input current at zero control flow (control ports blocked), expressed as nominal psi/mA or bar/mA throughout the range of load pressure between $\pm 40\%$ supply pressure.

Null – The condition where the valve supplies zero control flow at zero load pressure drop.

Null Bias – The input current required to bring the valve to null, excluding the effects of valve hysteresis, expressed as percent of rated current.

Null Shift – The change in null bias resulting from changes in operating conditions or environment, expressed as percent of rated current.

Frequency Response – The relationship of no-load control flow to input current when the current is made to vary sinusoidally at constant amplitude over a range of frequencies. Frequency response is expressed by the amplitude ratio in decibels (db) and phase angle in degrees (°) over a specific frequency range.

HYDRAULIC CHARACTERISTICS

Rated Flow: See Figure 1, page 9.

Frequency Response: Servo or Proportional Valve frequency response will vary with signal amplitude, supply pressure, and internal valve design parameters. The typical response varies with supply pressure as expressed by the change in frequency of the 90° phase point, as shown in figure 2. Note that Direct Drive Valve response is independent of system pressure.

Step Response: Servo or Proportional Valve step response will vary with amplitude, supply pressure and internal valve design parameters. See individual series catalogs for specifications. Full amplitude step responses will normally exhibit a straight line portion which represents flow saturation of the pilot stage. The slope of this straight line portion will vary with the square root of the change in supply pressure.

FIGURE 2
FREQUENCY RESPONSE CHANGE WITH PRESSURE

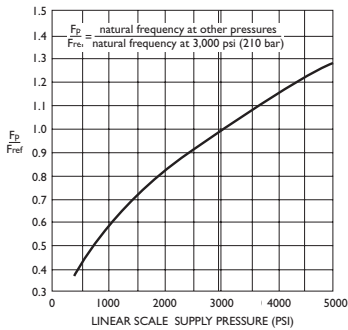
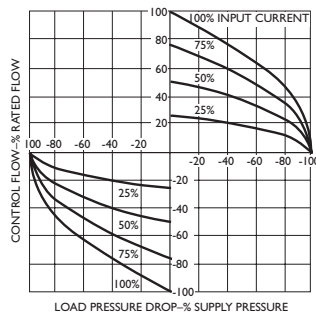

FIGURE 3
CHANGE IN CONTROL FLOW WITH CURRENT AND LOAD PRESSURE



Flow-Load Characteristics: Control flow to the load will change with various combinations of load pressure drop and electrical input, as shown in figure 3. These characteristics closely follow the relationship.

$$Q_L = Q_{NL} i \sqrt{P_V}$$

where:

Q_{NL} = no-load flow at 1,000 psi drop for Servovalves and 150 drop for P.V.

i = actual/rated current (%)

P_V = $(P_s - P_R) - P_L$

P_s = supply pressure

P_R = return pressure

P_L = load pressure drop

Q_L = control flow to the load

Internal Leakage: There are two sources of internal leakage; first, flow through the hydraulic amplifier (known as “tare flow”) which is relatively constant, and second, flow around the spool which varies with its position. Maximum internal leakage occurs at null. See individual Servo and Servo-Proportional Valve catalogs for specifications.

Spool Driving Forces: The maximum hydraulic force available to drive the second-stage spool will depend upon the supply pressure, multiplied by the end of the spool. In the case of Direct Drive Valves, spool driving force is created by the linear force motor and does not change with supply pressure.

Pressure Gain: A measure of the change in control port pressures as the input current is varied about the zero flow point. Pressure gain is measured against a blocked load under no flow conditions. Normally the pressure gain exceeds 30% of the supply pressure for 1% change in rated current and can be as high as 100%.

Null Bias: Input current to the valve required to adjust the output to zero flow. Most Moog Inc. valves have mechanical adjustments which allow the null bias to be externally adjusted.

PERFORMANCE CHARACTERISTICS

PERFORMANCE CHARACTERISTICS

Flow Gain: The no-load flow characteristics of Servo or Proportional Valves can be plotted to show flow gain, symmetry and linearity. Typical limits (excluding hysteresis effects) are shown in Figure 4.

Linearity: The nonlinearity of control flow to input current will be most severe in the null region due to variations in the spool null cut. With standard production tolerances, valve flow gain about null (within $\pm 5\%$ of rated current input) may range from 50 to 200% of the normal flow gain.

Rated Flow Tolerance: $\pm 10\%$

Symmetry: $< 10\%$

Hysteresis: typically $< 3\%$ for servovalves, $< .3\%$ for proportional valves

Threshold: typically $< .5\%$ for servovalves, $< .1\%$ for proportional valves

Null Shift:

With temperature: 100°F variation (56°C) $< \pm 2\%$

With acceleration: to 10 g $< \pm 2\%$

With supply pressure: $1,000\text{ psi}$ change (70 bar) $< \pm 2\%$

Characteristics

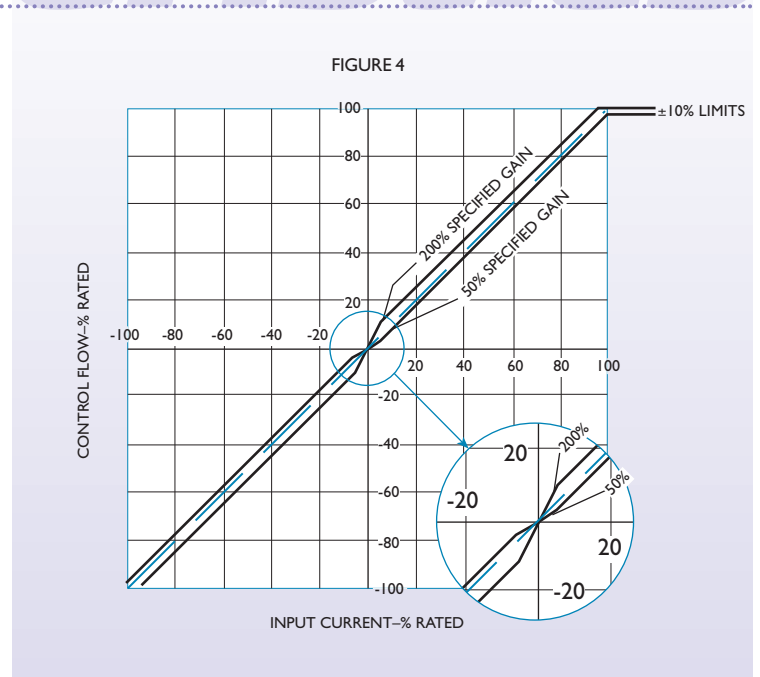

ELECTRICAL CHARACTERISTICS

INTRODUCTION

Moog's many electrohydraulic valve designs employ a number of different electrical connections. Mechanical Feedback Valves utilize the simplest electrical connections, while Electrical Feedback Valves can be more complex with different command signals, supply voltages and techniques to monitor actual spool position being employed. All Moog valves can be segmented into the following categories:

Valve Style	Electrical Connection	Command Signal
Mechanical Feedback Servovalve	4 pin	Current
Electrical Feedback Servovalve	6+PE pin	Voltage or Current
Direct Drive Servo-Proportional Valve	6+PE pin	Voltage or Current
ServoJet® Servo-Proportional Valve	6+PE pin	Voltage or Current
ServoJet® Servo-Proportional Valve	11+PE pin	Voltage or Current
DDV Pilot Servo-Proportional Valve	6+PE pin	Voltage or Current
DDV Pilot Servo-Proportional Valve	11+PE pin	Voltage or Current

MECHANICAL FEEDBACK VALVE ELECTRICAL CHARACTERISTICS

Rated Current and Coil Resistance: The specified input of either polarity to produce rated flow, expressed in milliamperes (mA). Rated current is specified for a particular coil configuration (differential, series, individual or parallel coils) and does not include null basis current.

Mechanical Feedback Standard Electrical Configuration: Standard electrical connections and electrical polarity for flow out of left control port when viewing valve from pressure side area are:

- single coil: A+, B-; or C+, D-
- series coil: tie B to C; A+, D-
- parallel coils: tie A to C and B to D; [A & C]+, [B & D]-

Coil Connections: A four pin electrical connector that mates with a MS3106R14S-2S or equivalent is standard. All four coil leads are available at the connector, allowing external connections for signal, series, or parallel coil operation.

Servoamplifier: A Servovalve responds to input current. Therefore, in order to reduce the effects of coil resistance variations, a Servoamplifier with high internal impedance (as obtained with current feedback) should be used.

Dither: A small amplitude, high frequency sinusoidal signal may be used to reduce friction and hysteresis effects within the valve, improving system performance. If used, the peak-to-peak amplitude should be less than 10% of rated signal. Since the desired frequency is dependent on the valve style, consult factory for recommended frequency.

Coil Impedance: The two coils in each Servovalve are wound for equal turns with a normal production tolerance on coil resistance of $\pm 12\%$. Copper magnet wire is used, resulting in a coil resistance that will vary significantly with temperature. The effects of coil resistance changes can be essentially eliminated through the use of a current feedback Servoamplifier having high output impedance.

Inductance is determined under pressurized operating conditions and varies greatly with signal frequencies above 100 Hz.

Intrinsically Safe: Optional intrinsically safe designs are available for most standard valve models. These designs have been granted both entity and loop approval by Factory Mutual (FM), CSA and Cenelec. Please consult factory for the latest CSA information on hazardous location approvals.

ELECTRICAL CONNECTIONS

Connector MS3106R14S-2S

Parallel

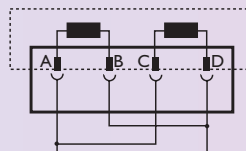

A and C (+)
B and D (-)

Series

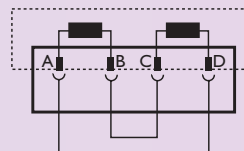

A (+), D (-)
B and C connected

Single

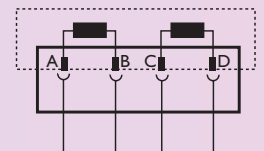

A (+), B (-)
or C (+), D (-)

Connectors for Valve Opening
P \blacktriangleright B, A \blacktriangleright T

ELECTRICAL FEEDBACK VALVE ELECTRICAL CHARACTERISTICS

Supply Voltage: An electrical feedback always employs an on-board position transducer and often times has the valve control electronics on-board. Thus Electrical Feedback Valves require a supply voltage. Supply voltages for some models are 24 VDC (19 VDC min. and 32 VDC max.), while others require ± 15 VDC ($\pm 3\%$).

Input Signals: There are two basic options for command signals for Electric Feedback Valves – voltage and current. Each valve series may offer different options, so consult individual data sheets for choices. For voltage commands, the spool stroke of the valve is proportional to differential input (V_D and V_E). The valve is opened 100% (opening P \blacktriangleright A and B \blacktriangleright T) by a maximum voltage ($V_D - V_E$) command. A voltage command that is in the midpoint of the voltage command range results in the spool being centered. If only one command signal is available, pin D or E is connected to signal ground. For current commands, the spool stroke of the valves is proportional to I_D or I_E . The valve is opened 100% (opening P \blacktriangleright A and B \blacktriangleright T) by a maximum current ($I_D - I_E$). A current command that is in the midpoint of the current command range results in the spool being centered.

Measuring Spool Position: Electric Feedback Valves permit the monitoring of actual spool position by measuring the signal from pin F. The output signal can be either current or voltage. Check individual valve series data sheets for specific options. The amplitude of the output signal is proportional to spool position.

6+PE Electrical Configuration: Moog offers up to three configurations of electrical connections for its Electric Feedback Valves. See page 14 for details. They are available on:

- Direct Drive Servo-Proportional Valves
- ServoJet[®] Servo-Proportional Valves
- Electrical Feedback Servovalves

11+PE Electrical Configuration: Moog also offers a 11+PE connector for its D660, D680 and D691 Series Valves. This connector allows additional monitoring of the valve, including dequate supply voltage and position error logic. See page 14 for details.

Shielding: All signal lines should be twisted pairs and shielded. Shielding connected radially to Z (0V), power supply side, and connecting to the mating connector housing (EMC) should be used.

EMC: All Electrical Feedback Valves, that employ on-board or integrated electronics; meet the requirements of EN 55011/3.91 class B, EN 50081-1/01.92, and EN 50082-2/03.95 performance criterion class A.

Explosion Proof: Valves are available with explosion proof protection to EN 50018, class EEx d II C-C₂H₂T5.

systems
systems

ELECTRICAL CHARACTERISTICS

DIRECT DRIVE SERVO-PROPORTIONAL VALVES 6+PE Electrical Configuration

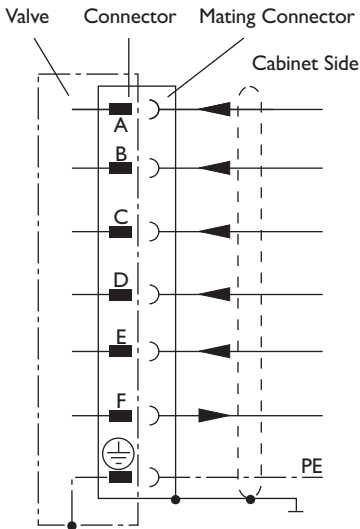

Function	Voltage Command 0...±10VDC	Current Command 0...±10 mA	Current Command +4...+20 mA
Supply	+24VDC (22 to 28VDC)		
Supply/Signal Ground	⊥ (0V)		
Not Used			
Input Command Valve Flow	0...±10VDC Input Resistance = 50 kΩ	0...±10 mA Load Resistance = 200 Ω	+4...+20 mA Load Resistance = 200 Ω
Input Inverted Command Valve Flow	0...±10VDC Input Resistance = 50 kΩ	0...±10 mA Load Resistance = 200 Ω	Not Used
Output Actual Spool Position	100% flow out port B @ +4 mA 100% flow out port A @ +20 mA Load Resistance 300 to 500 Ω with respect to ⊥ (0V)		
Protective Grounding			

SERVOJET® SERVO-PROPORTIONAL VALVES 6+PE Electrical Configuration

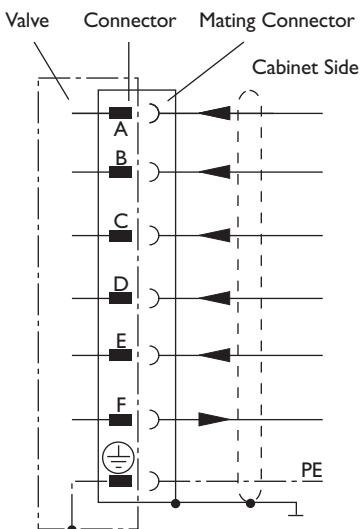

Function	Voltage Command		Current Command
Supply	24 VDC (min. 19 VDC, max. 32 VDC)		I _{max} : 300 mA
Supply/Signal Ground	⊥ (0V)		
Enabled Not Enabled	V _{C-B} > 8.5 VDC V _{C-B} < 6.5 VDC		I _e = 1.2 mA at +24 VDC
Input Rated Command (differential)	V _{D-E} : 0...±10 V R _e : 10 kΩ	V _{D-B} and V _{E-B} : max.: -15 V max.: +24 V	Input Command Referenced to ⊥ I _{D-B} : 0...±10 mA (Load Resistance 200 Ω) Input Command (Inverted) Ref. to ⊥ I _{D-B} : 0...±10 mA
Output Actual Value	V _{F-B} : +2.5...+13.5 V. At +8 V spool in centered position R _a : ca 15 kΩ		
Protective Grounding			

ELECTRICAL FEEDBACK SERVOVALVES

6+PE Electrical Configuration

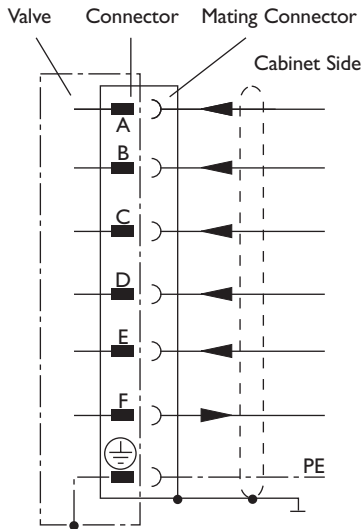

Function	Voltage Command	Current Command
Supply	+15 VDC $\pm 3\%$, ripple < 50 mV _{pp}	
Supply	-15 VDC $\pm 3\%$, ripple < 50 mV _{pp}	
Supply/Signal Ground	\perp (0V)	
Input Command Valve Flow	0... ± 10 VDC Input Resistance = 10 k Ω	0... ± 10 mA Load Resistance (diff.) = 1 k Ω
Input Inverted Command Valve Flow	0... ± 10 VDC Input Resistance = 10 k Ω	0... ± 10 mA Load Resistance (diff.) = 1 k Ω
Output Actual Value Spool Position	0... ± 10 VDC Load Resistance = 1 k Ω	0... ± 10 mA Load Resistance max. = 500 Ω
Protective Grounding		

SERVOJET® SERVO-PROPORTIONAL VALVES

11+PE Electrical Configuration

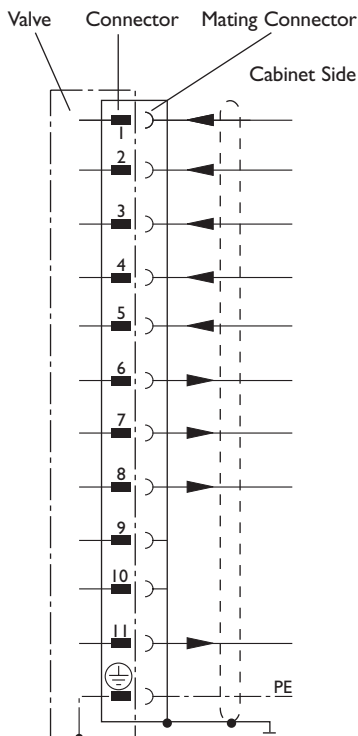

Function	Voltage Command	Current Command
Supply	24 VDC (min. 19 VDC, max. 32 VDC) I_{max} : 300 mA	
Supply/Signal Ground	\perp (0V)	
Enabled Not Enabled	$V_{3-2} > 8.5$ VDC $V_{3-2} < 6.5$ VDC	$I_e = 1.2$ mA at +24 VDC
Input Rated Command (differential)	V_{4-5} : 0... ± 10 V R_e : 10 k Ω	V_{4-2} and V_{5-2} : max.: -15 V max.: +24 V Input Command Referenced to \perp I_{4-2} : 0... ± 10 mA (load resistance 200 Ω) Input Command (Inverted) ref. to \perp I_{5-2} : 0... ± 10 mA
Output Actual Value (differential)	V_{6-7} : 0... ± 10.5 V R_a : ca 20 k Ω	
Enable and Supply Acknowledged	$V_{8-2} > 8.5$ VDC: ok $V_{8-2} < 6.5$ VDC: not ok	Output I_{max} : 20 mA
Not Used		
Not Used		
Position Error, Logic	$V_{11-2} > 8.5$ VDC: < 30% $V_{11-2} < 6.5$ VDC: > 30%	Output I_{max} : 20 mA
Protective Grounding		

NOZZLE FLAPPER SERVOVALVE OPERATION

TORQUE MOTOR

- Charged permanent magnets polarize the polepieces.
- DC current in coils causes increased force in diagonally opposite air gaps.
- Magnetic charge level sets magnitude of decentering force gradient on armature.

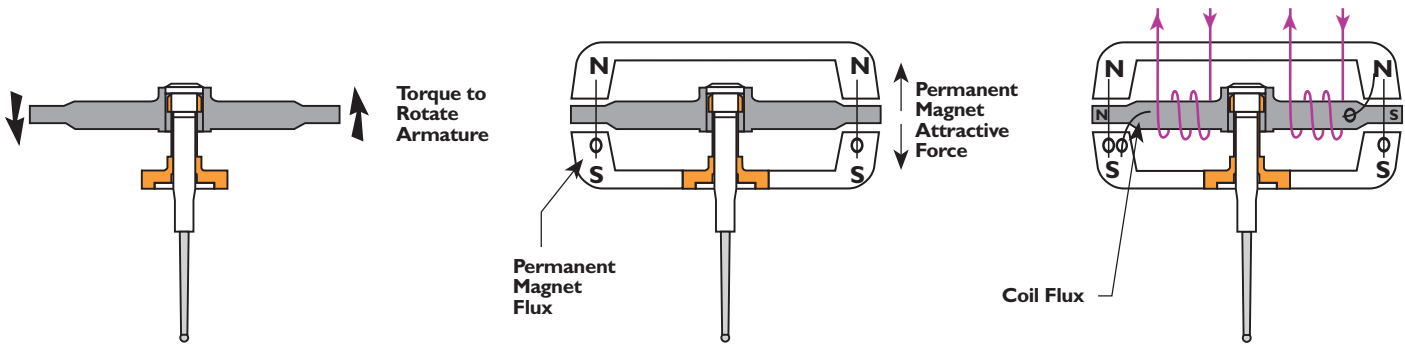
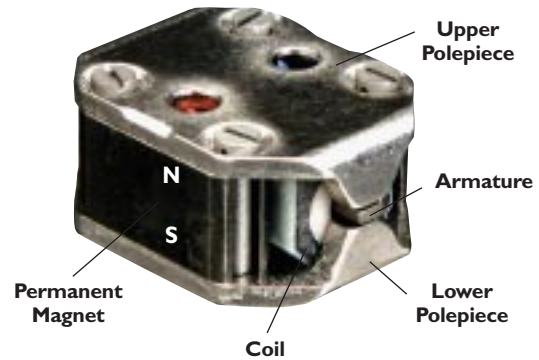

HYDRAULIC AMPLIFIER

- Armature and flapper rigidly joined and supported by thin-wall flexure sleeve.
- Fluid continuously flows from pressure P_s through both inlet orifices, past nozzles into flapper chamber, through drain orifice to tank T.
- Rotary motion of armature/flapper throttles flow through one nozzle or the other.
- This diverts flow to one end of the spool.

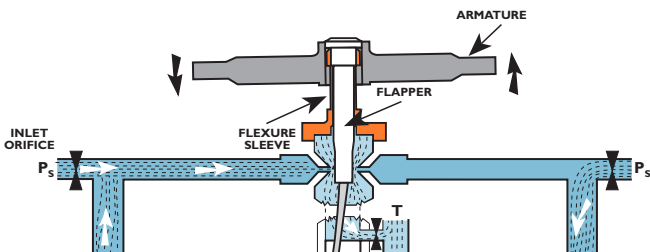

VALVE SPOOL

- Spool slides in bushing (sleeve) or directly in body bore.
- Bushing contains rectangular holes (slots) or annular grooves that connect to supply pressure P_s and tank T.
- At "null" spool is centered in bushing; spool lobes (lands) just cover P_s and T openings.
- Spool motion to either side of null allows fluid to flow from P_s to one control port and from other control port to T.

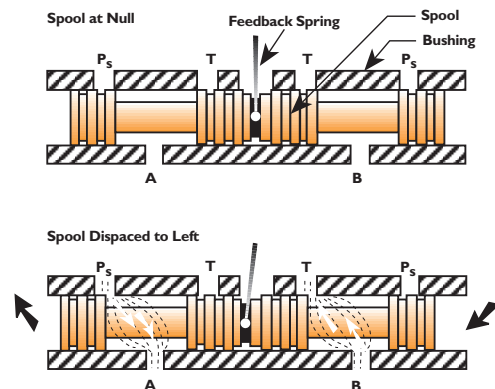

Operation

Valve Responding to Change in Electrical Input

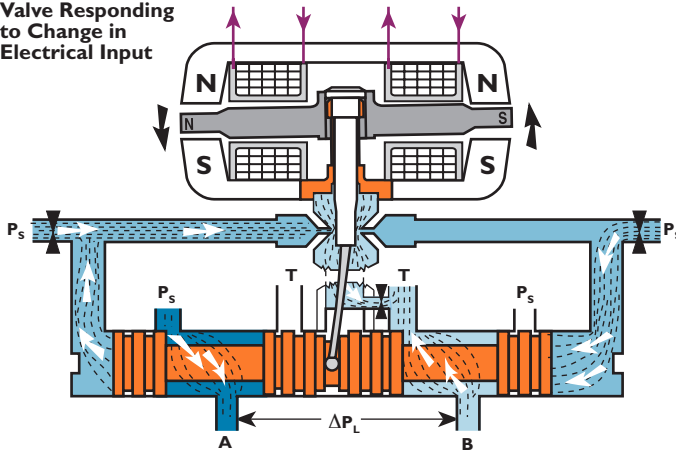

Valve Condition Following Change

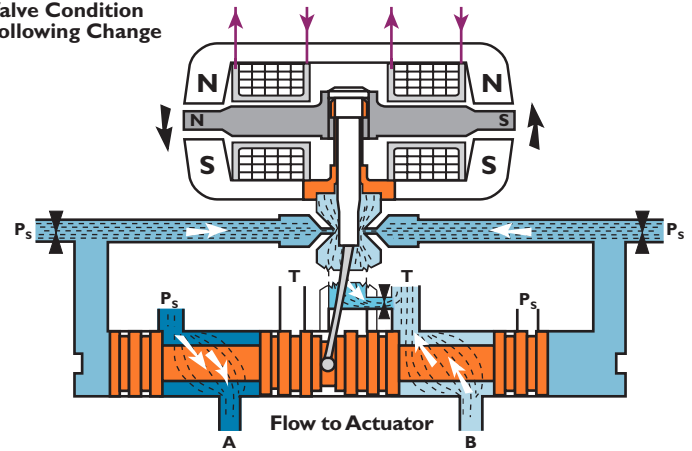

OPERATION

- Electrical current in torque motor coils creates magnetic forces on ends of armature.
- Armature and flapper assembly rotates about flexure sleeve support.
- Flapper closes off one nozzle and diverts flow to that end of spool.
- Spool moves and opens P_s to one control port; opens other control port to T.
- Spool pushes ball end of feedback spring creating a restoring torque on the armature/flapper.
- As feedback torque becomes equal to torque from magnetic forces, armature/flapper moves back to centered position.
- Spool stops at a position where feedback spring torque equals torque due to input current.
- Therefore, spool position is proportional to input current.
- With constant pressures, flow to load is proportional to spool position.

SERVOJET® SERVO-PROPORTIONAL VALVE OPERATION

SERVOJET® PILOT STAGE

- The ServoJet® pilot stage consists mainly of torque motor, jet pipe, and receiver.
- A current through the coil displaces the jet pipe from its neutral position. This displacement, combined with the special shape of the nozzle, directs a focused fluid jet from both receivers towards one receiver.
- The jet now produces a pressure difference in the control ports.
- This pressure difference results in a pilot flow, which in turn causes a spool displacement. The pilot stage drain is through the annular area around the nozzle to tank T.

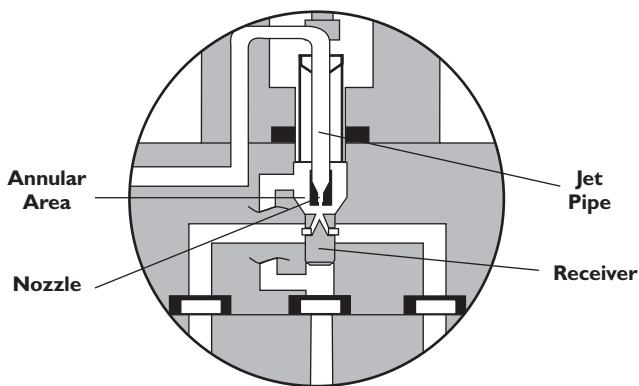

OPERATION

- An electrical command signal (flow rate set point) is applied to the integrated position controller which drives the valve coil.
- The current through the coil displaces the jet pipe from its neutral position.
- The displacement of the jet directs the flow to one end of the spool.
- Spool moves and opens P to one control port, while the other control port is open to tank T.

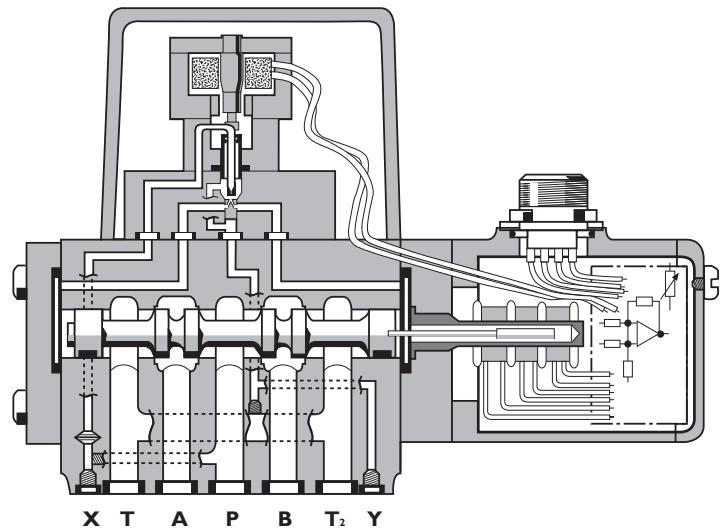

VALVE SPOOL

- Spool slides in bushing (sleeve) or directly in body bore.
- Bushing contains rectangular holes (slots) or annular grooves that connect to supply pressure P_s and tank T.
- At “null,” spool is centered in bushing; spool lobes (lands) just cover P_s and T openings.
- Spool motion to either side of null allows fluid to flow from P_s to one control port, and from other control port to T.
- The position transducer (LVDT), which is excited via an oscillator, measures the position of the main spool (actual position voltage).
- The signal for the actual position of the spool is then demodulated and fed back to the controller, where it is compared with the command signal.
- The controller drives the pilot valve until the error between command signal and spool position feedback signal is zero.
- Thus, the position of the main spool is proportional to the electrical command signal.

DIRECT DRIVE SERVO-PROPORTIONAL VALVE OPERATION

LINEAR FORCE MOTOR

- > A linear force motor is a permanent magnet differential motor.
- > The motor consists of a coil, pair of high energy rare earth magnets, armature, and centering springs.

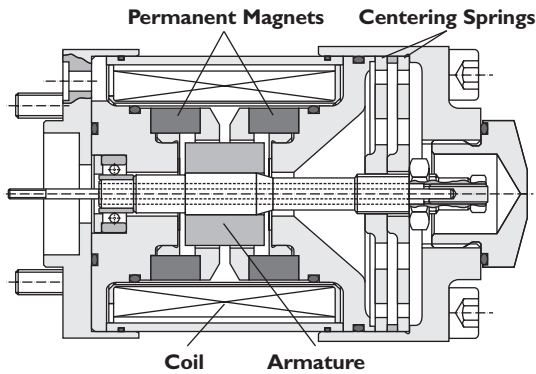

- > Without a current being applied to the coil, the magnets and springs hold the armature at equilibrium.

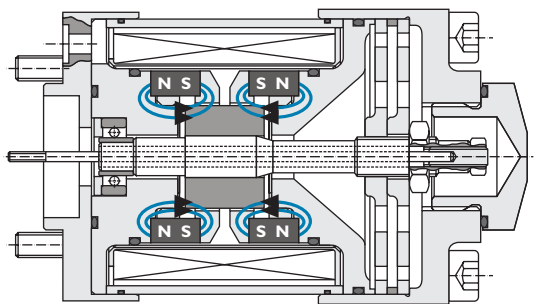

- > When current is applied to the coil with one polarity, the flux in one of the air gaps surrounding the magnets is increased, cancelling out the flux in the other.
- > This dis-equilibrium allows the armature to move in the direction of the stronger magnetic flux.

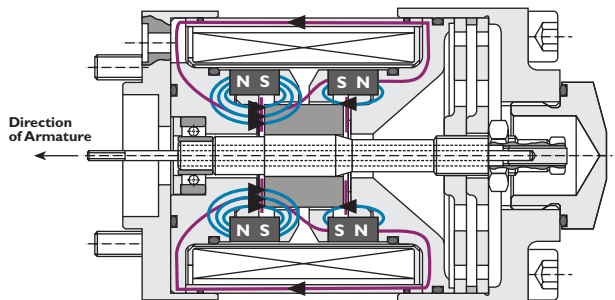

- > The armature is moved in the opposite direction by changing the polarity of the current in the coil.

VALVE SPOOL

- > Spool slides in bushing (sleeve) or directly in body bore.
- > Bushing contains rectangular holes (slots) or annular grooves that connect to supply pressure P_s and tank T.
- > At "null," spool is centered in bushing; spool lobes (lands) just cover P_s and T openings.
- > Spool motion to either side of null allows fluid to flow from P_s to one control port, and from other control port to T.

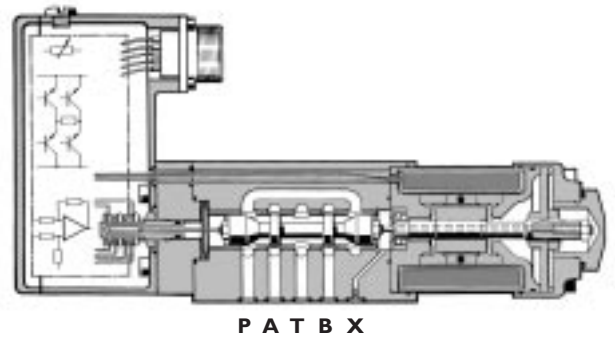

OPERATION

- > An electrical signal corresponding to the desired spool position is applied to the integrated electronics and produces a pulse width modulated (PWM) current in the linear force motor coil.
- > The current causes the armature to move which then directly activates the spool.
- > The spool moves and opens pressure P to one control port, while the other control port is opened to tank T.
- > The position transducer (LVDT), which is mechanically attached to the spool, measures the position of the spool by creating an electrical signal that is proportional to the spool position.
- > The demodulated spool position signal is compared with the command signal, and the resulting electrical error drives current to the force motor coil.
- > The spool moves to its commanded position and the spool position error is reduced to zero.
- > The resulting spool position is thus proportional to the command signal.

PRACTICAL CONSIDERATIONS WHEN LAYING OUT ELECTROHYDRAULIC CONTROL SYSTEMS

I. Power Units

Pumps:

- Constant supply pressure is preferred with minimum variation. Use accumulators with variable displacement pressure compensated pumps. Fixed displacement pump: constant pressure with use of accumulator is an option.
- If more than one critical system is fed from one pump, isolate each system with check valves and accumulators (avoids cross-talk).
- Reservoir breather: 3 to 5 micron air filter preferred with capacity appropriate to fluid displacement.
- Temperature and pressure should be closely controlled if good long term control accuracy is critical.
- Fluid flowing over a relief valve represents wasted energy.

2. Piping and Fittings

Do not use pipe dope. (It contains fine, hard to filter, particulate.)

Use TFE tape when necessary. Do not use pipe or pipe fittings.

- Use only correct tube cutting tools, no hacksaw. Deburr if necessary.
- Cold bending preferred.
- Descale after hot bending and welding. Rotating joints can generate contamination.
- Flexible lines: if unavoidable use teflon, nylon or thermoplastic lined hoses rather than rubber (neoprene) which eventually shed particles. Place flex lines before filter, not after.
- Use O-ring fittings rather than tapered pipe type. If pipe fittings cannot be avoided, use Teflon tape.

3. Filtration

The Moog filtration philosophy is summarized as follows:

- Use a 10 to 15 micron absolute non-bypass high pressure filter just before the Servo or Proportional Valve.
- Use a 3 micron low pressure filter in the return line, if possible.
- Use a 3 to 5 micron low pressure filter in an off-line filtration loop.
- Recirculate oil in reservoir more than 5 times per hour.

This is justified on the bias that:

- The Servo or Proportional Valve can accept the odd particle up to 25 microns.
- It is neither practical nor economical to try to clean the oil with a small, relatively expensive, high pressure element. The cheaper, low pressure element is many times larger and has the potential to filter continually and under more ideal conditions. (Steady flow and lower velocities increase filtration efficiency.)

- In the case where large changes of oil volume in the reservoir occur, as with a single ended hydraulic cylinder, it is suggested that a 3 micron low pressure element be used as an air breather.
- Always use dirt alarms/pressure switches to enable changing of elements at correct intervals.
- Use cheaper low-pressure flushing elements to flush the system on start-up – remember that new oil is “dirty oil,” having picked up contaminant in transit and packaging.
- The tank volume should be flushed through the filter at least 50 times, changing the element when indicated by the pressure switch (contaminate alarm), or until the system has operated 6 to 8 hours without the need for a flushing element change.

4. Servo and Proportional Valve –

Characteristics of Major Importance:

- Frequency response (time constant)
 - Threshold (resolution)/hysteresis
- #### 4.1 Placement:
- Mount as near as possible to the actuator to reduce the entrapped oil volume. Oil is compressible and can often limit servo response.
 - Flexible lines between valve and actuator can be rarely justified. As a rule of thumb they decrease stiffness to one-third of the volume that they contain. Additionally, they produce contamination which must pass through the valve. Use only nylon, teflon or thermoplastic lined hose.
- #### 4.2 Sizing:
- Select the valve size to obtain between 1/4 and 1/3 system pressure (P_s) drop across the valve at maximum velocity. If the drop across the valve is too small, then a flow change will not take place until the valve is nearly closed.
 - Remember: to control flow the valve must drop pressure across itself. Too large a valve is a waste, or worse than that, it lowers system resolution.

5. Actuator (cylinder/motor)

- Size the area for dynamic and static forces (remembering the 1/4 to 1/3 P_s requirement of the Servo or Proportional Valve in the dynamic case).
- Calculate the resonant frequency and adjust the actuator areas and valve size, if necessary, to optimize accuracy. (Increased area plus increased natural frequency improves accuracy.)
- Recognize the 2% to 20% breakout friction of different seals and their effect on position resolution.
- Manifolds should not contain air pockets. If they do, you cannot flush the air out of the manifold, leading to a “soft” system.
- Keep the cylinder full area/rod end area ratio ≤ 2:1 to avoid greatly differing extend and retract velocities.

Note:

$$\frac{\text{extend velocity}}{\text{retract velocity}} = \sqrt{\frac{\text{full area}}{\text{rod end area}}}$$

5.1 Actuator Connection to Load and Frame:

- There should be no free play (a practical limit in a position loop would be 3 to 10 times less than the required position accuracy).
- The mechanical stiffness should normally be 3 to 10 times higher than hydraulic stiffness to avoid degrading performance.
- Gearing down decreases inertia felt at actuator and hence increases natural frequency (and with it system response and accuracy). However, gearing down could lower stiffness and introduce play/backlash due to the gears.

6. Feedback Transducer

Closes the loop and its characteristics are of paramount importance, e.g.:

- Linearity
- Threshold (resolution) and hysteresis
- Drift with temperature or time
- Frequency response (it must be 3 to 10 times faster than the slowest element in the system).

6.1 Transducer Placement:

- Placing at the actuator output eliminates many control problems (by excluding secondary spring-mass systems and play), but may not provide accuracy at the point required.

7. Servoamplifier

- The dynamics of the analog electronics are always better than the Servovalve and spring-mass system. Therefore, they can be neglected.
- Some digital systems, however, lack the level of dynamics that are needed. In order to see if this is a problem, check the following:
 - (i) That the update rate of the PLC is a maximum of 20 times faster than the frequency of the valve.
 - (ii) That the update rate of a digital-to-analog converter, which is required for Electric Feedback Servovalves, is faster than the valve. A rule of thumb is that the converter should be a minimum of 20 times faster, and preferably 100 times faster than the 90° frequency of the valve.
 - (iii) Use of 12 and 16 bit digital-to-analog converters. Anything slower could compromise the valves resolution.
 - (iv) The last stage to the Servovalve is a current output.
- Use of compensation techniques (Proportional, Integral or Derivative) can be reviewed when selecting the Servoamplifier. (Note that 90% of position loops can be handled by a straight ‘P’ controller, and the simplicity of set up and troubleshooting a ‘P’ controller is invaluable).
- Avoid placing the amplifier close to electric motor controllers or other components that generate high electromagnetic fields – consider shielding if necessary.
- Interconnection to the command signal and feedback transducer should use shielded cables to minimize interference. (Ground only the chassis end to prevent ground loops.)

8. Conclusion

To lay out a design for a Servosystem means taking care of minimizing lags in the control chain. (In addition to the usual design requirements of strength, fatigue life, ease of maintenance, ease/cost of manufacture, etc.)

Lags may be caused by:

1. Free-play/backlash/stick-slip
2. Free-time constants of components

The time constant of the valve can be selected. However, the time constant of the actuator-mass system is dependent upon the control of hydraulic and structural stiffness and the mass of moving parts.

ROUTINE MAINTENANCE FOR SERVO AND PROPORTIONAL VALVES

1. As a general rule, hydraulic components should not be disturbed while they are operating normally.
 - This rule particularly applies to Servo or Proportional Valves.
 - They should not be removed unless trouble-shooting has shown that they are malfunctioning.
 - If the system must be “opened” (for example, adding new pipework, hoses, valves or actuators), then the valve should be removed, replaced by a flushing plate and the new system start-up procedure followed.
2. If the valve must be removed, the area around the subplate should be thoroughly cleansed using non lint producing materials before raising the valve from the surface.
 - If the valve function is critical, a spare Servo or Proportional Valve should always be held in stock. The spare should be fitted in place of the removed valve and the shipping plate placed on the removed valve. The valve should be returned to Moog Inc. for service. A newly installed valve may develop a fault soon after fitting if care is not taken with cleanliness.
 - Where no spare valve exists the surface should then be covered by a clean plastic sheet so as to limit the possibility of contaminants entering the system. The valve should be returned to Moog Inc. for service.
3. Some valves are fitted with manual override operators. Most have null adjust screws. No other adjustments are possible in the field, apart from the null adjustment. The style of this adjustment varies with different valves. Consult individual valve series data sheets for details.
4. The torque motor is a precision device. Do not attempt to remove or dismantle. Permanent and expensive damage can result. Likewise, do not try to remove the spool in the main stage. Return the valve to Moog Inc. for service.
5. Moog Inc. will not partially repair a valve. Our policy is to always return the valve to its original specification. In so doing it will always be returned with a 24 month new valve warranty.
6. Moog Inc. Servo and Proportional Valves are used when precision control is required. The Servovalve is a precision instrument and consistency in performance is not possible with “dirty oil.”
7. There are two considerations in filtration for Servo and Proportional Valves.
 - 7.1 Particle Contamination:

Larger particles from approximately 40 microns and upwards can lodge in the Servovalves’ pilot stage filter screen. Particles smaller will generally pass through. This is a last chance filter and is not intended as a system filter. See page 20 for filtration details.
 - 7.2 Silt Contamination:

This can, under certain circumstances, lead to seizure of the main spool in the bushing. However, this is rare due to the very high spool positioning forces employed. Silt does affect valve life by eroding the sharp metering edges on the valve spool and bushing.
8. Contamination Control
Contamination enters the fluid at many points:
 - 8.1 New oil supplied from refineries contains noticeable residue in the bottom of empty drums. Particles of 100 micron and larger are quite usual in new oil.
 - 8.2 Filling Methods:

Contamination can enter via dirty funnels or other unhygienic filling methods. Moog Inc. recommends a transfer pump upstream of the 3 micron low pressure filter. When in doubt, remove the valve, fit a flushing block and flush the system out before refitting the valve.
 - 8.3 Airborne Contaminants:

Many factories have very dusty air in the vicinity of the hydraulic power unit. Sometimes the dust is corrosive. In systems with large air flows in and out of the reservoir, Moog Inc. recommends a 3 micron breather filter.
 - 8.4 Airborne contaminants are also collected on the rod end of hydraulic cylinders and are drawn into the cylinder in varying amounts, depending on rod wiper efficiency. These are normally collected in the 3 micron low pressure filter.
 - 8.5 Contaminants from rubber hose, teflon tape, metal silt particles from wearing valves, pumps, etc. all contribute to fluid contamination.

Maintenance

9. How often do I change the fluid?

Fluid change frequency depends on whether the filtration quality is high, oil temperature is maintained at reasonable levels, moisture condensation is low, and the oil is not breaking down. Regular observations of oil color in the sight glass are sufficient for monitoring the condition of the fluid. If it remains clear and machine operation is normal, do not change the fluid. There is no firm and fast rule for fluid change. Hydraulic system fluids are not like the oils in engines, as they are not subject to continuous chemical contamination. If the fluid is scheduled to be changed at a time when filters are not showing indication of contamination, then leave the old filter elements in for one or two days before changing them for new elements. Where the hydraulic power unit is dedicated to the valve alone, it may be several years before an oil change is necessary. Where the valve is fed from a larger power unit which services other functions, a more frequent change will be necessary.

10. Adjusting the Null on a Valve.

As stated in section 3, no other field adjustment exists on a valve other than the null adjustment. This is set at the factory and should not normally be disturbed. If a valve is indicating an excessive null drift, it may be indicative of contamination. The null adjustment allows the spool to be centered and thus limit any actuator motion when the valve electrical signal is zero. It is preferable to disconnect the valve connector when carrying out this adjustment. With critical axis cut spools, the null may drift slightly with temperature change and valve age. One to two percent drift is permitted as it will be corrected with the closed loop control in operation. For instructions on how to adjust the null of a valve, see individual valve series data sheets.

11. Test Equipment.

It is difficult to troubleshoot a closed loop system to isolate which components are faulty. The simplest way to check a valve is to use a valve tester. Moog offers valve testers for its valves. Model M040-119 is for Mechanical Feedback Valves, while our M040-104 Series is for both Electrical Feedback Valves with integrated electronics and Mechanical Feedback Valves. These testers allow the valve to be driven with a controlled command signal, either positive or negative, from an independent source. It allows the Servoactuator to be positioned or moved about its stroke length and to observe proportionality between command and speed. Measurement of the position feedback signal can be carried out at any point along the stroke.



